

440G-LZ

Description

The Guardmaster 440G-LZ is a guard-locking interlock switch for use on partial body access guards. It has a rated holding force of 1,300N. The switch functions by a locking bolt extending into the actuator preventing the opening of a guard. It has two OSSD solid-state outputs that are only enabled when the locking bolt is extended and detected as entered into the actuator. The locking bolt will only attempt to extend when the correct actuator is detected. It can be used as part of a guard locking system to achieve performance Level "e" to EN/ISO 13849-1 and certified by the TÜV as meeting EN/ISO 13849-1 performance level "e" for both position and lock monitoring.

Advanced algorithms and a bi-stable solenoid result in low energy use. Peak power only occurs when changing from unlocked to locked (or vice versa). The bi-stable drive uses minimal power and will not produce heat when either locked or unlocked. The functionality is configured to replicate a traditional power-to-release or power-to-lock device

The RFID actuators can be selected as either standard or uniquely coded. The user can select the level of actuator coding according to the foreseeable risk of tampering in accordance with the requirements of EN/ISO 14119:2013

Each switch has semiconductor OSSD safety outputs that can be connected in series with other safety components that also have OSSD solid-state outputs. On-board twin LEDs enable visual diagnostics. An auxiliary output is also included as well as a manual release.

This switch can be used in washdown applications as found in the food and beverage, pharmaceutical, and semiconductor industries because of its IP69k rating with stainless steel metal parts and a design that is hygiene compliant.



ATTENTION: With the 440G-LZ "power-to-lock" style, provisions may be required to ensure that a dangerous situation can not result from open circuit faults or power cuts.

Features

- Certified to PLe to EN/ISO 13849-1 (both for door position and lock monitoring to EN/ISO 14119)
- Solid-state design and monitored outputs
- Scalable protection with unique or standard coded RFID actuators
- High holding force of 1,300 N (Fzh)
- Energy efficient green device that only uses 2.5 W
- IP69k and hygienic design
- Power-to-release and power-to-lock versions
- Compact design optimized for ease of mounting
- Diagnostic information provided by two bright 270° LEDs
- Solid-state OSSD outputs series connectable to EN/ISO 14119:2013

Specifications

Safety Ratings	
Standards	IEC 60947-5-3, IEC 60947-5-1, IEC 61508, EN ISO 13849-1, IEC 62061, ISO 14119, UL 508
Safety Classification	PLe Category 4 per ISO 13849-1, SIL 3 per IEC 61508 and IEC 62061
Functional Safety Data Guard door sensing and lock monitoring	PFHd: 9.1 x 10 ⁻¹⁰ ; Dual channel interlock can be suitable for use in application up to PLe (according to ISO 13849-1) and for use up to SIL3 systems (according to IEC 62061 and IEC 61508) depending on application characteristics. Mission time/PTI: 20 years
Certifications	CE Marked for all applicable EU directives, cULus (UL 508), TÜV, Ctick
Operating Characteristics	
Torque for M5 mounting of switch and actuator mounting bracket	2 Nm max.
Locking bolt insertion for assured locking & holding force	Min. of 5 mm (0.19 in.), max. of 10 mm (0.39 in.)
Locking bolt alignment tolerance X, Y, Z	Max. of ±2.5 mm (0.09 in.)
Holding Force Fmax (EN/ISO 14119)	1,690 N
Holding Force Fzh (EN/ISO 14119)	1,300 N
Maximum output current (each outputs)	200 mA
Quiescent power consumption, locked or unlocked	2.5 W
Peak current and duration, at turn on or after lock/unlock operation	400 mA / 100 ms
Operating voltage Ue	24V DC +10% / -15% Class 2 SELV
Maximum frequency of operating cycles	0.2 Hz
Dwell time between subsequent locking/unlocking	2.5 s
Response time (Off)	100 ms first switch, 50 ms additional for each switch
Risk Time (according to IEC 60947-5-3)	100 ms
Start up time (availability)	5 s
Maximum length of a chain of switches	10 km (Dependent on cable/ connection/required response time)
Utilization category (IEC 60947-5-2)	DC-13 24V 200 mA
Insulation voltage Ui (IEC 60947-1)	75V
Impulse withstand voltage Uimp (IEC 60947-1)	1 kV
Pollution degree (IEC 60947-1)	3
Manual (auxiliary) release	Built in
Protection class (IEC 61140)	Class II
Mechanical life	500,000 cycles
Outputs (Guard door closed and locked)	
Safety Outputs	2 x PNP, 0.2 A max / ON (+24V DC)
Auxiliary Outputs	1 x PNP, 0.2 A max / OFF (0V DC)
Environmental	
Operating temperature [C (F)]	0...+55° (+14...+131°)
Storage temperature [C (F)]	-25...+75° (-13...+167°)
Operating humidity	5...95% relative
Enclosure ingress rating	NEMA 3, 4X, 12, 13, IP66, IP67, IP69k
Shock and vibration	IEC 60068-2-27 30 g, 11 ms/IEC 60068-2-6 10...55 Hz
Hygienic	ISO 14159:2004 and EN 1672-2005, (for that part of the machine defined as "food splash area")
Washdown	Sodium Hydroxide based washdown fluids
Radio frequency / EMC	IEC 60947-5-3, FCC-1(Parts 18&15), R&TTE
General	
Materials	ABS, locking bolt and mounting bracket 304 stainless steel
Weight switch/actuator	Switch 400 g, actuator 150 g, actuator mounting bracket 60 g
Protection Type	Short-circuit, current limitation, overload, reverse polarity, overvoltage (up to 60V max.), thermal shutdown/restart

Product Selection

Complete Switch (including switch body, actuator and actuator mounting bracket)

Locking Type	Actuator Type	Cat. No.		
		Connector Type		
		3 m Lead	10 m Lead	6-in. Pigtail with M12 8-Pin QD
Power to release	Standard (low level to EN/ISO 14119:2013)	440G-LZS21SPRA	440G-LZS21SPRB	440G-LZS21SPRH
	Unique (high level to EN/ISO 14119:2013)	440G-LZS21UPRA	440G-LZS21UPRB	440G-LZS21UPRH
Power to lock	Standard (low level to EN/ISO 14119:2013)	440G-LZS21SPLA	440G-LZS21SPLB	440G-LZS21SPLH
	Unique (high level to EN/ISO 14119:2013)	440G-LZS21UPLA	440G-LZS21UPLB	440G-LZS21UPLH

Accessories

Spare Actuators

Locking Type	Actuator Type	Cat. No.
Power to release	Standard (low level EN/ISO 14119:2013)	440G-LZASPR
	Unique (high level EN/ISO 14119:2013)	440G-LZAUPR
Power to lock	Standard (low level EN/ISO 14119:2013)	440G-LZASPL
	Unique (high level EN/ISO 14119:2013)	440G-LZAUPL

Mounting Brackets

Description	Cat. No.
Actuator mounting bracket	440G-LZAM1
Switch body mounting bracket	440G-LZAM2

Approximate Dimensions

Dimensions are shown in mm (in.). Dimensions are not intended to be used for installation purposes.

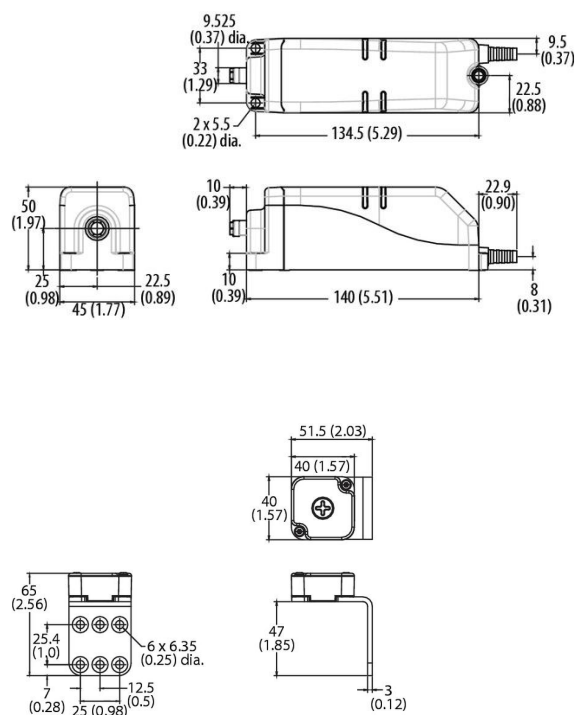

Typical Wiring Diagrams

8-Pin Micro (M12)

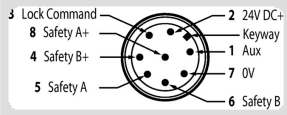

8-Pin Cordset
889D-F8AB* or cable version

Color	Function	Pin
White	Aux	1
Brown	24V DC +	2
Green	Lock	3
Yellow	Safety B+	4
Grey	Safety A	5
Pink	Safety B	6
Blue	Gnd/0V	7
Red	Safety A+	8